

NEW

SPARK PAT. PEND SOLAR PANEL CLEANING

Optimal and economical solution for cleaning and washing solar panels

NAANDANJAIN
A JAIN IRRIGATION COMPANY

Thanks to innovation and the technological advances, we now have ways of replacing fossil fuels with more environmentally-friendly and renewable energy sources. Sunlight is one of those energy sources. Using solar panels (PV), we can harness the energy of the Sun and transform it into electricity.

Due to the increasing demand for energy and increasing cost effectiveness solar electricity, more and more of the earth's surface is being covered with solar panels.

Both households and energy companies are generating electricity in this way. Regardless of the purpose of the panels, their efficiency means income.

In order for the panels to properly absorb the sunlight, they must be as clean as possible. Once there is dirt of any kind - sand, dust and even bird droppings - on the surface of the panels, they become less efficient, and the production of electricity is compromised. Some reports mention losses of up to 30% in electricity generation as a result of dirt.



This is where we come in:

NaanDanJain has come up with the perfect solution - **Spark**, the solar panel cleaning unit!

It is an optimal and economical solution for the cleaning and washing of solar panels. We make sure you won't have to climb your roof again or worry about cleaning your endless number of panels. Instead, you can be rest assured that your solar energy facility is producing electricity full throttle!

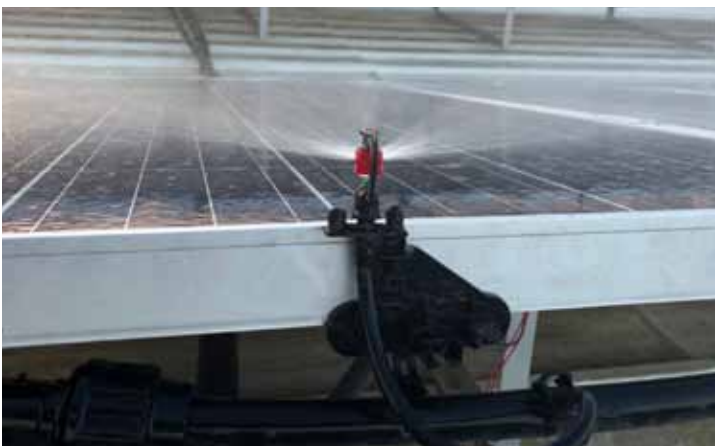

Benefits

- **Increase electricity generation:** enables the system to keep producing more efficiently.
- **Saves money:** no need to hire any cleaning services.
- **Saves labor:** manual cleaning of the panels becomes obsolete.
- **Saves time:** no time invested in maintaining and cleaning the system.
- **Safety:** eliminates the need for elevated handling and cleaning risks.

Maintenance

Using a proper water source is crucial. Water containing high concentrations of bicarbonate, calcium, magnesium and salts might create sediments in the long run. Adequate water treatment recommended to reduce hardness of water used.

STRUCTURE AND FEATURES:

- Unique adjustable **Spark** unit that fits most panels in the market.
- The **Spark** unit maintains steady, well-aligned micro-sprinklers on the panels for optimal cleaning.
- Uniform cleaning of the panel.
- The **Spark** unit is free of vibration while cleaning the solar panels, unlike other solutions in the market
- All components are modular and easy to assemble without a need for special tools.
- Easy, user-friendly assembling and dismantling of the unit on the panel.
- Two kinds of water distribution for best coverage of the area: The main **Spark** unit consists of a 180° static diffuser, while the second Spark unit consists of a 90° static diffuser for use on the edges and boundaries.
- Non-rotating parts for long life span even under tough conditions, such as high temperatures, wind and dust.

Operations

It is better to operate the **Spark** units daily, preferably early in the morning. At dawn, the surface of the panels is wet and covered with dew. Thus enabling the Spark units to clean the panels with less amount of water.

The optimal duration of operation of the **Spark** units varies from 15 to 25 seconds, depending on the severity of the surrounding conditions and the amount of dirt build-up.

Positioning and adjustments

The following table shows the recommended number of **Spark** units per lateral.

The higher the diameter of the lateral, the more **Spark** units you can install on it.

NUMBER OF MICRO-WASHERS FOR DIFFERENT LATERAL DIAMETERS	
Lateral diameter (mm) (grade 4)	Flow Rate (l/h) (at 2 bars)
	105
	Number of Spark units
16	12
20	20
25	30
32	50

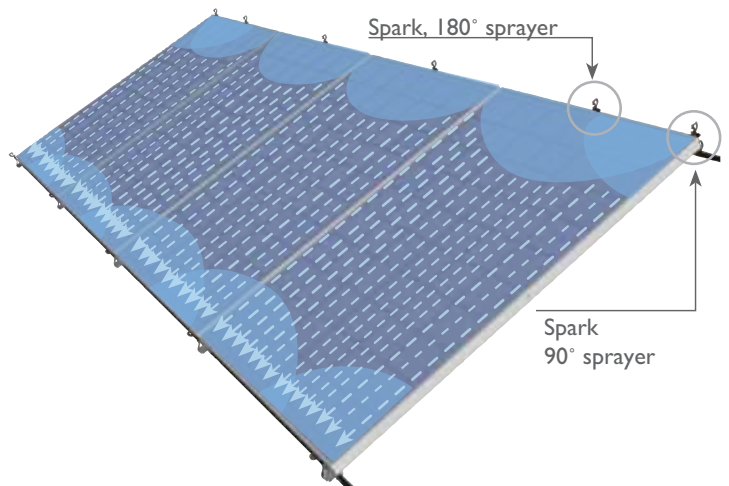

TECHNICAL DATA

- Recommended working pressure: 1.5-2.5 bar
- Filtration requirement: 200 microns

SPARK NOZZLE AND FLOW RATE VS. PRESSURE

Color	Flow rate (l/h)	Nozzle ID (mm)	Pressure (bar)			
			1.5	2.0	2.5	3.0
Green	105	1.41	91	105	117	129

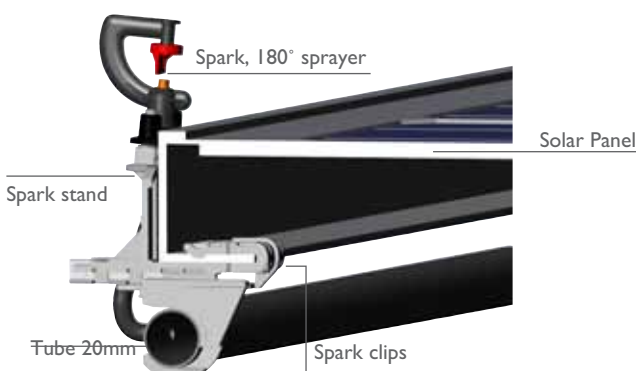

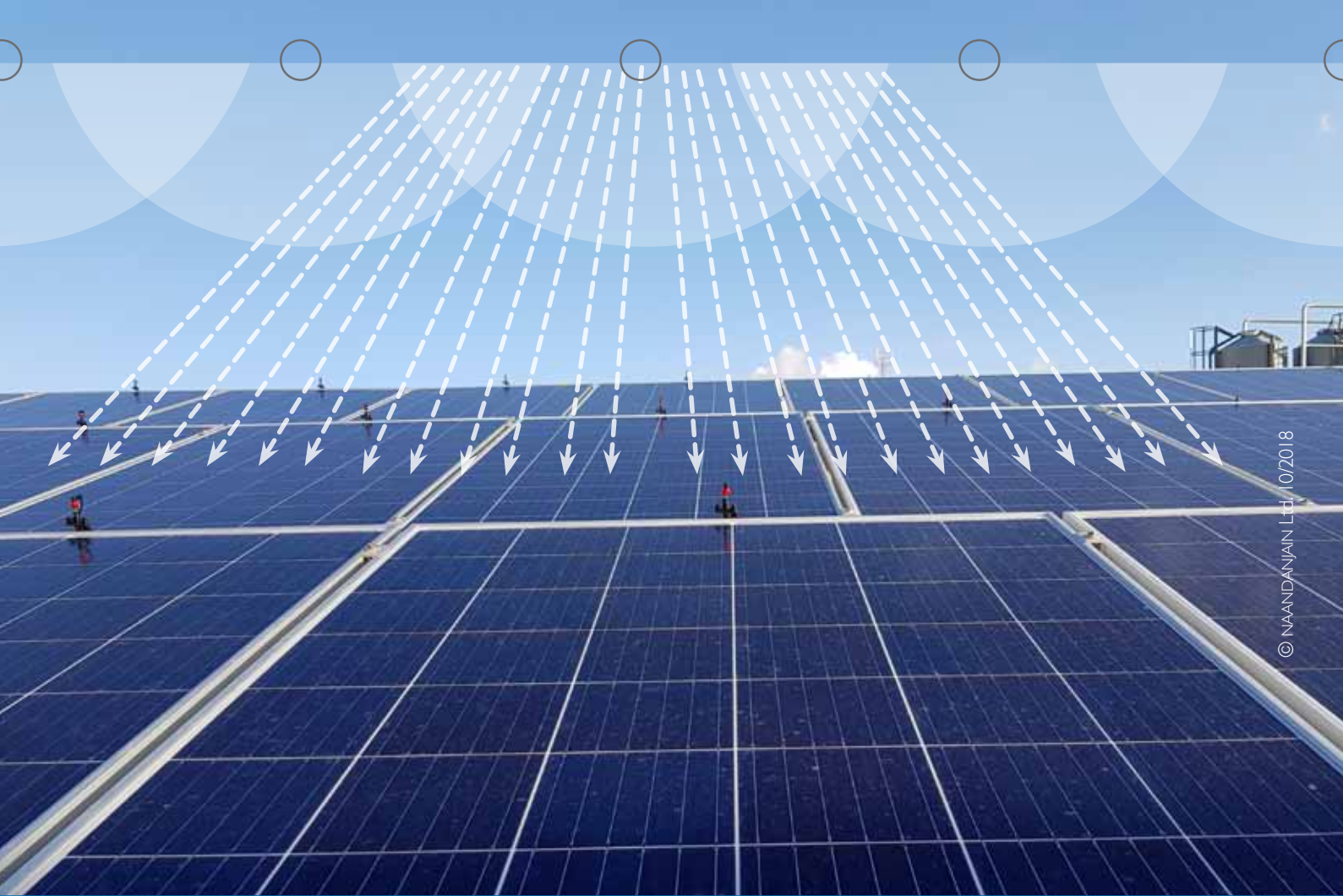

© NAANDANJAIN LTD. / 10/2018

Optimal and economical solution for cleaning and washing solar panels

Before & After cleaning

Spark 180° & Spark 90°



© 2018 NaanDanJain Ltd. All rights reserved.
All specifications are subject to change without notice.