

Arkal 1½” Super Filter

Catalog No. 012004-*****

Features

- A “T” shaped filter with two 1½” male threads.
- A “T” volume filter for in-line installation on 1½” pipelines.
- The filter prevents clogging due to its enlarged filtering area that collects sediments and particles.
- Manufactured entirely from fiber reinforced plastic.
- A cylindrical column of grooved discs constitutes the filter element.
- A sealing spring keeps the discs compressed.
- Screw-on filter cover.
- Filter discs are available in various filtration grades.

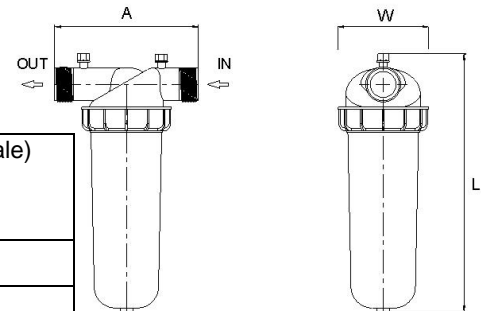

Technical Data

Inlet/outlet diameter	1½” BSPT (male)	1½” NPT (male)
	40 mm – nominal diameter	
	48.2 mm – pipe diameter (O. D.)	
Maximum pressure	10 bar	145 psi
Maximum flow rate	12 m³/h (2.22 l/sec)	52.8 gpm
General filtration area	500 cm²	77.5 in²
Filtration volume	600 cm³	37 in³
Filter length L	350 mm	13 ²⁵ / ₃₂ ”
Filter width W	130 mm	5 ³ / ₃₂ ”
Distance between end connections A	200 mm	7 ⁷ / ₈ ”
Weight	1.51 kg	3.32 lbs.
Maximum temperature	70° C	158° F
pH	5-11	5-11

Filtration Grades

- Blue (400 micron / 40 mesh)
- Yellow (200 micron / 80 mesh)
- Red (130 micron / 120 mesh)
- Black (100 micron / 140 mesh)
- Green (55 micron)

Headloss Chart

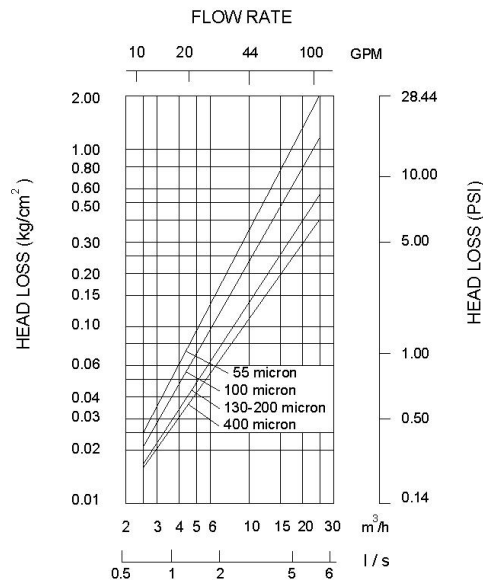

Installation

1. Filter may be installed either vertically or horizontally.
2. Use Teflon tape on filter end connections.
3. Never use spanners for tightening the filter cover.

Maintenance

If the filter discs are covered with lime deposits then remove the element and treat with chloric acid.

Dismantling

1. Turn off the water.
2. Make sure that the pressure is released from the filter.
3. Unscrew the cover from the filter body.
4. Pull out the filter element.
5. Move the sealing ring to the end of the spine.
6. Flush the discs with the water jet.

Assembly

1. Verify that the tightening spring is placed at the bottom of the filter cover.
2. Assemble in reverse order.
3. Tighten the cover by turning the fixing nut clockwise and don't over tighten.

Part List – 1 1/2" Super Filter

No.	Cat. No.	Description	Materials
1	710101-000148	GAUGE PORT NUT	RPP
2	770104-000045	GAUGE PORT SEAL	EPDM
3	710101-000854	FILTER ADAPTOR RING	RPA
4	710101-000131	STOP RING FOR ELEMENT	PBT
5	700101-*****	DISC SET *** Micron	PP / PE
6	710101-000069	SPINE	RPA
7	770101-000012	90x4 O-RING	NR
8	760107-000005	FILTER SPRING	SS
9	710101-000048	FILTER COVER	RPA
10	730104-000006	1/4" TAP (*)	BRASS
11	710101-000849	FIXING NUT	RPA
12	700101-001199	FILTER ELEMENT 130 Micron	
13	710101-000853	1" FILTER WRENCH	RPA
14	700190-000072	FILTER BODY COMPLEX BSP	
	700190-000073	FILTER BODY COMPLEX NPT	

(*) - OPTIONAL

Materials

- R.P.P. – REINFORCED POLYPROPYLENE
- R.P.A. – REINFORCED POLYAMIDE
- S.S. – STAINLESS STEEL
- PP – POLYPROPYLENE
- PE - POLYETHYLENE
- N.R. – NITRILE RUBBER
- P.C. – POLYCARBONAT

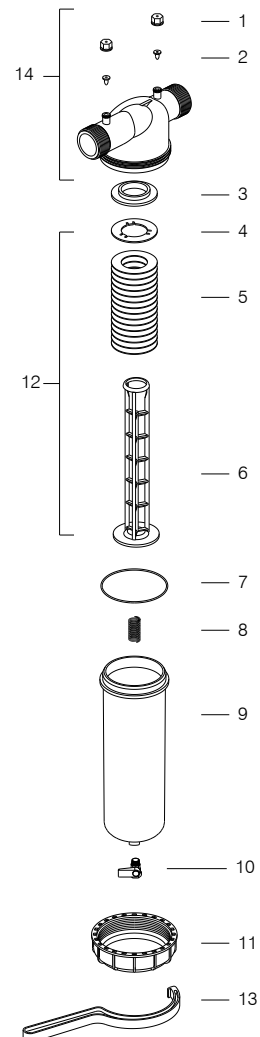
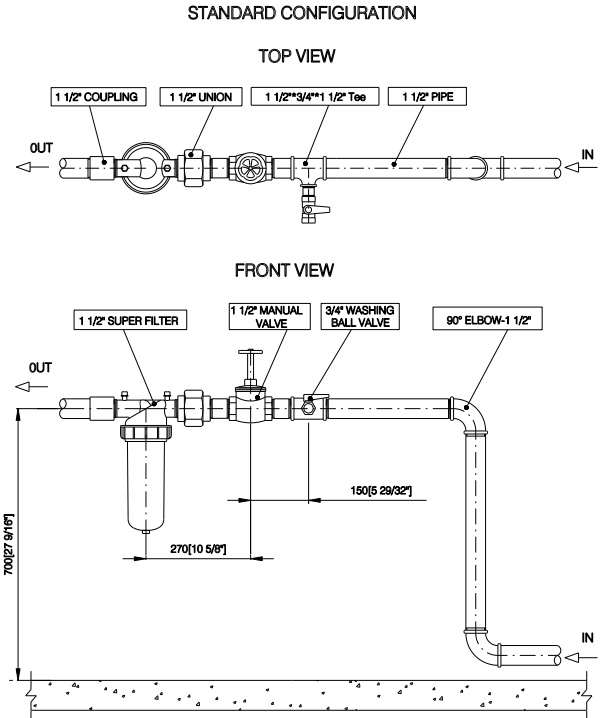

AMIAD LIMITED WARRANTY

This certificate applies to Amiad Products purchased by You from Amiad or an Amiad authorized Distributor (“**Distributor**”). This limited warranty extends only to the original purchaser, and is not transferable to anyone who subsequently purchases, leases, or otherwise obtains the Product from the original purchaser.

1. Amiad hereby warrants that the Products are and will be free from defects in material and workmanship under normal use and service. Amiad warrants that it will correct manufacturing defects in the Products, in accordance with the conditions set out in this warranty.
2. This warranty is enforceable for a period of 12 months after the date Bill of Lading or equivalent (the “**Warranty Period**”).
3. In the event that during the Warranty Period the Distributor discovers a defect in material and/or workmanship in any Product or part (the “**Defective Product**”), it shall submit a written complaint to Amiad using Amiad's standard customer complaint form. For the receipt of the customer complaint form, the submission of the complaint or any questions please contact your customer service representative.
4. Upon written demand by Amiad the Distributor shall return the Defective Products – or a sample thereof – to Amiad, at Amiad's cost. If the customer ships any such Product, Amiad suggests the customer package it securely and insure it for value, as Amiad assumes no liability for any loss or damage occurring during shipment. Provided however that in the event Amiad determines that the warranty does not apply to such Product, Distributor shall promptly reimburse Amiad for such cost (including freight and customs). Any returned Product or part must be accompanied by the warranty certificate and the purchase invoice. It is clarified that the Distributor may not return the Defective Product unless such return was coordinate and approved by Amiad in advance.
5. Amiad's obligation under this warranty shall be limited to, at its option, the repair or exchange, free of charge, of the Product or any part which may prove defective under normal use and service during the Warranty Period. The provision of a repaired or replacement Product during the Warranty Period will result in an extension of the Warranty Period by an additional period of 12 months, provided that the total accumulated Warranty Period shall in any event be no more than 18 months from the original Bill of Lading.
6. This warranty is valid on the condition that the Products are installed according to Amiad's instructions as expressed in Amiad's instruction manuals and according to the technical limitations as stipulated in Amiad's literature or as stated by a representative of Amiad.
7. This warranty will not apply to damaged or defective Products resulting from or related to:
 - (i) Fire, flood, power surges or failures or any other catastrophe/and or unforeseen occurrence, such as but not limited to those for which the customers are customarily insured;
 - (ii) Fault, abuse or negligence of the customer;
 - (iii) Customer's responsibilities, including the failure of the intake water to meet the agreed standards, as set forth in a written document, approved by Amiad or improper storage.
 - (iv) Improper or unauthorized use of the Product or related parts by the customer, including the customer's failure to operate the Product in conformity with the recommendations and instructions of Amiad, as set forth in Amiad's manuals and other written materials, the operation of the Product other than by a trained and qualified operator, or improper installation of the Product by a third party not authorized by Amiad;
 - (v) Performance by the customer of maintenance and other services other than by a trained and qualified advanced operator, or other than in conformity with the recommendations and instructions of Amiad, or other than in accordance with procedures defined in the literature supplied for Products;
 - (vi) Any alteration, modification foreign attachment to or repair of the Products, other than by Amiad or its authorized technical representatives.
8. In no event shall Amiad be liable to the customer or any third party for any damages, including indirect, special, exemplary, punitive or consequential damages, or lost profits arising out of or in connection with this warranty, or arising out of or in connection with the Product's performance or failure to perform, even if it has been advised of the possibility of such damages.
9. Amiad will be excused for failure to perform or for delay in performance hereunder if such failure or delay is due to causes beyond its reasonable control or force majeure preventing or hindering performance.
10. The limited warranty set forth herein is the only warranty given by Amiad and is provided in lieu of any other warranties created by any documentation, packaging or otherwise.
11. Amiad makes no warranty whatsoever in respect of accessories or parts not supplied by Amiad. In the event that Amiad is required to correct a defective Product or product not covered by this warranty, it will do so solely in consideration for additional fees.